



**LW F28**  
**Q0QT-SP01-260ZA**

**GB**

## **12V FLOOR CLEANER**

**Original Instructions**

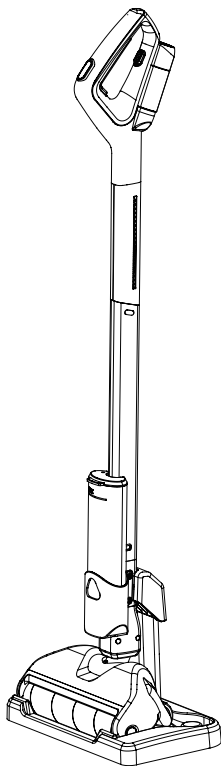

**READ & UNDERSTAND INSTRUCTION MANUAL**

**Save all warnings and instructions for future reference.**

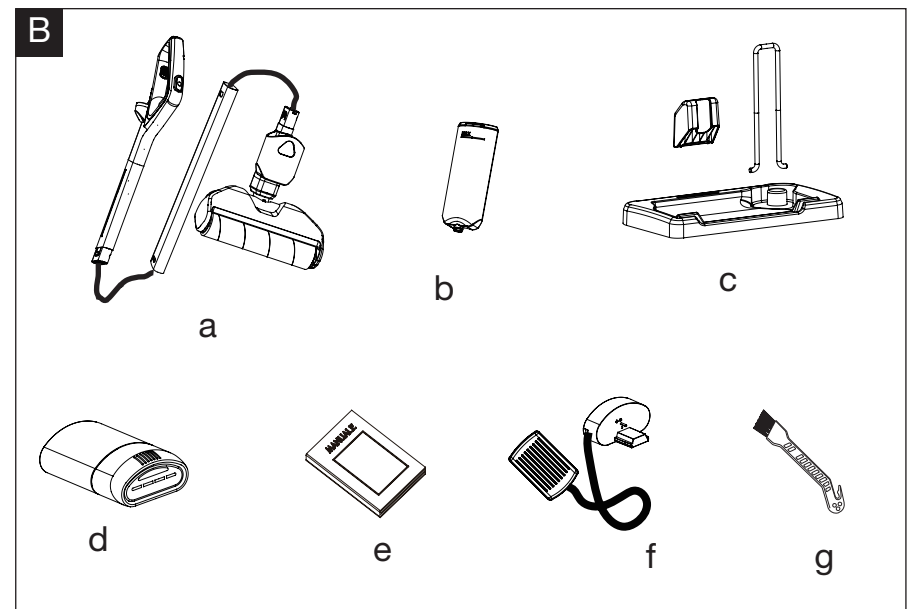
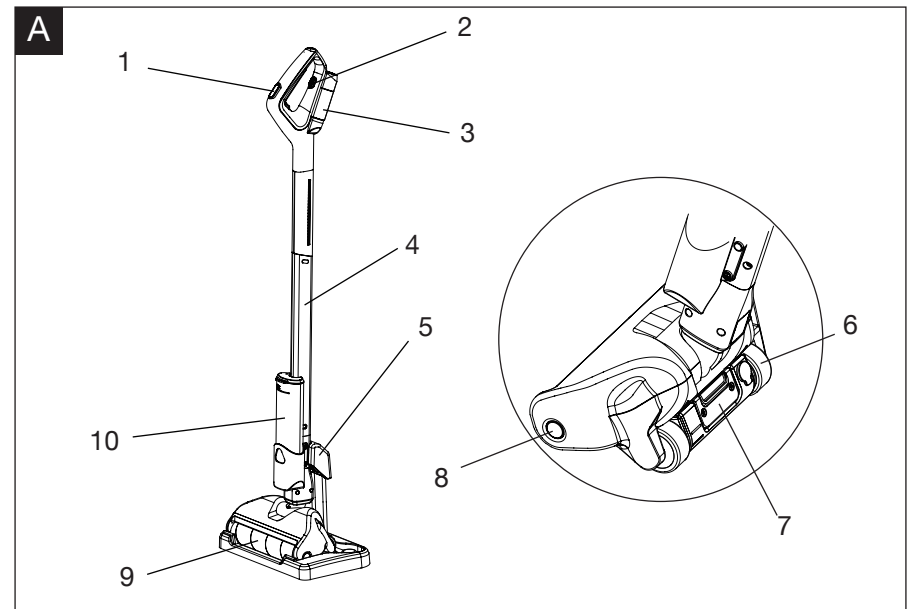

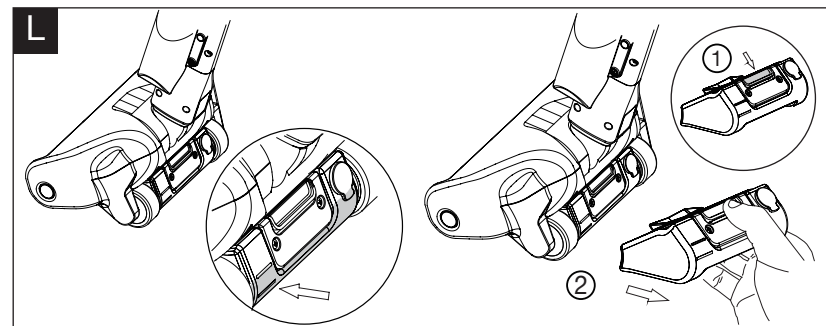
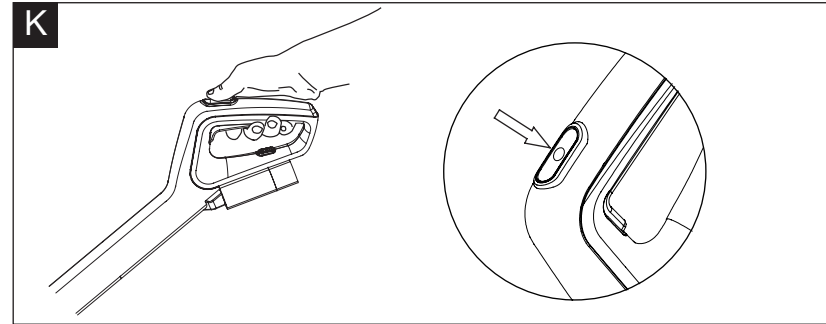
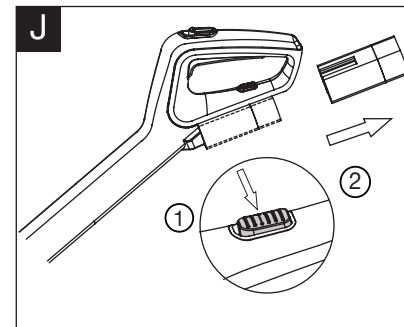
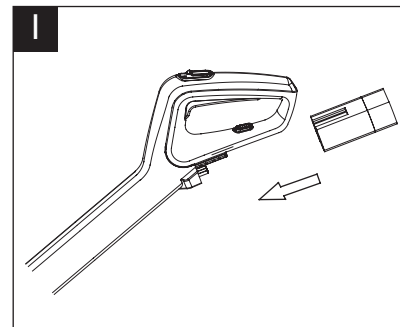
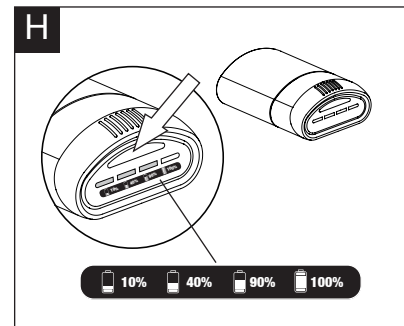
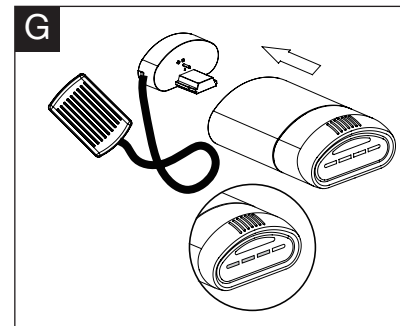
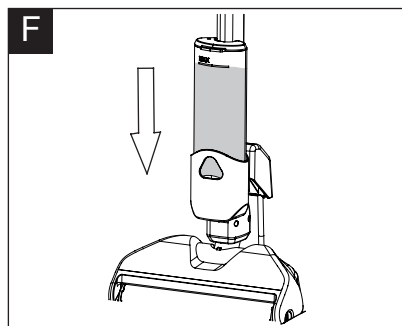
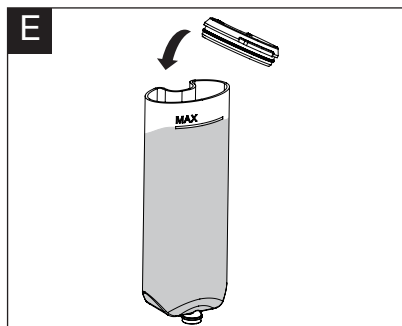
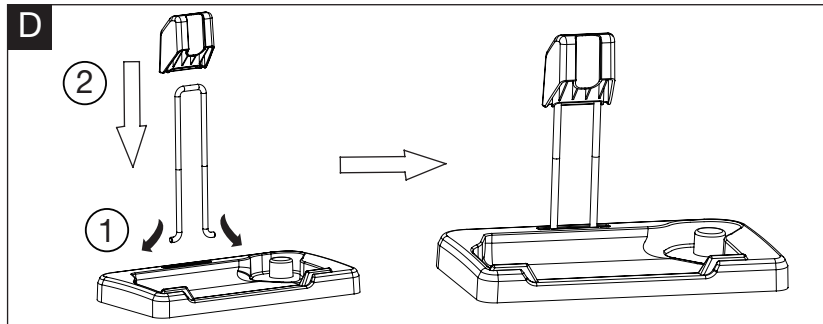
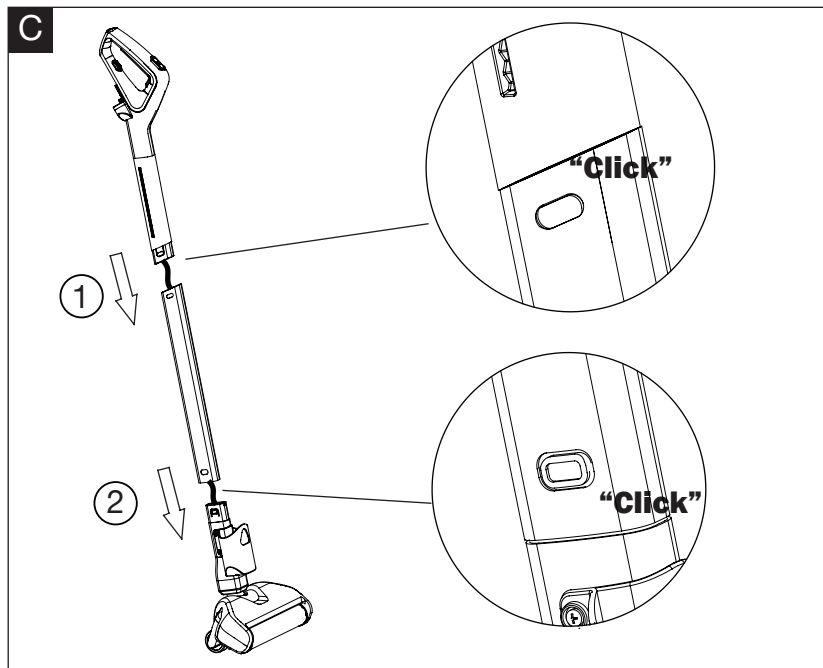

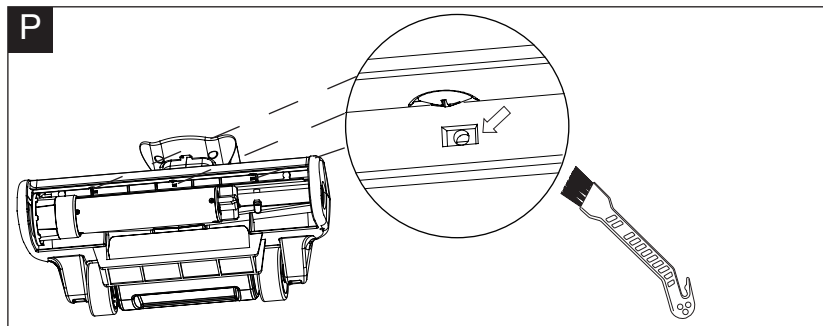
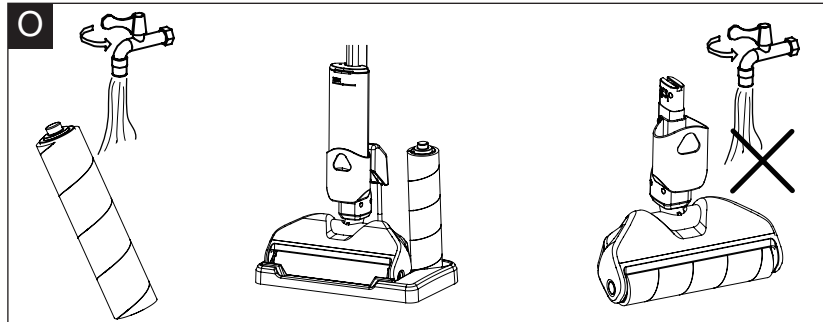
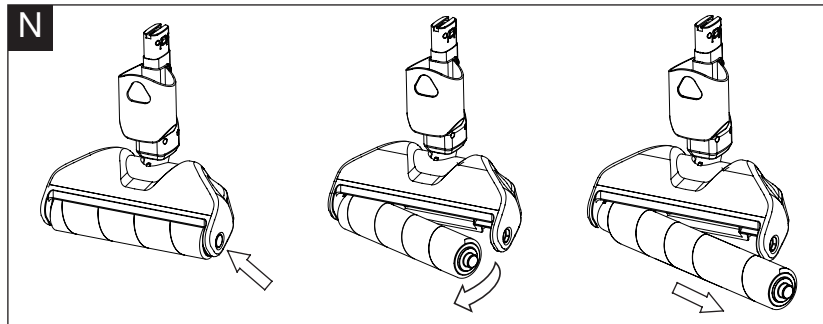
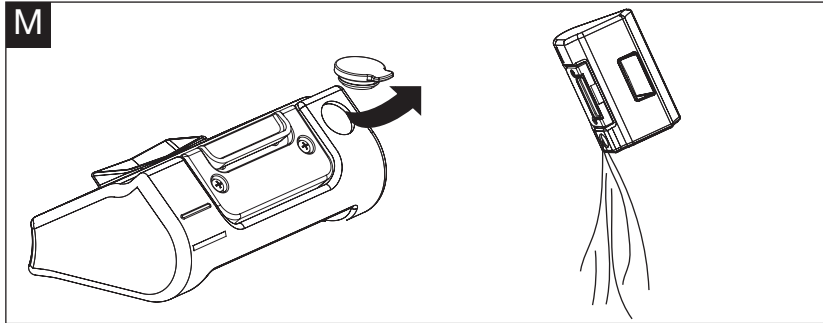

# YARD FORCE

## LW F28 Original Instruction

### CONTENT

Intended use	08
General safety warnings	08
Symbols	15
Technical data	19
Description of product	20
Installation	21
Operation	22
Maintenance and storage	25
Troubleshooting	26
Declaration of conformity	27

## INTENDED USE

Use the floor cleaner exclusively for cleaning hard floors in your private household and only on waterproof hard floors.

Do not clean water-sensitive floor coverings such as untreated cork floors (the moisture could penetrate and damage the floor).

The device is suitable for cleaning PVC, linoleum, tiled, stone and all water resistant floor coverings.

Please note that our equipment has not been designed for use in commercial, trade or industrial applications. Our warranty will be voided if the machine is used in commercial, trade or industrial businesses or for equivalent purposes.

## GENERAL SAFETY WARNINGS

- Apart from the notes contained herein the general safety provisions and rules for the prevention of accidents of the legislator must be observed.
- Warnings and notes that are attached on the appliance provide important notes for the safe operation.

### Hazard levels

#### **DANGER!**

Point to immediate danger, which leads to severe injuries or death.

#### **WARNING!**

Point to a possibly dangerous situation, which can lead to severe injuries or death.

#### **CAUTION!**

Point to a possibly dangerous situation, which can lead to minor injuries.

#### **ATTENTION!**

Point to a possibly dangerous situation, which can lead to property damage.

## GENERAL SAFETY WARNINGS

### Electric components

#### **DANGER!**

- Do not immerse the device into water.
- Check the faultless condition of the appliance and the accessories before using it. Otherwise, the appliance must not be used.
- Immediately replace the charger with the charging cable in case of visible damage.
- Turn off the appliance and remove the mains plug prior to any care and maintenance work.
- Repair works may only be performed by the authorized customer service.
- The appliance contains electrical components - do not clean under running water.
- Do not insert conductive objects (such as screwdrivers or the like) into the charging socket.
- Do not touch contacts or wires.
- The voltage indicated on the type plate must correspond to the supply voltage.
- Do not scrape the power cord across sharp edges and ensure that it does not get pressed.

#### **WARNING!**

The appliance may only be connected to alternating current. The voltage must correspond with the type plate of the appliance.

## GENERAL SAFETY WARNINGS

### Charger

1. Recharge only with the charger specified by the manufacturer. Do not use the original charger on other Li-Ion batteries or on any other type of battery as this can increase the risk of fire or explosion.
2. Check the battery charger, cable, and plug before each use. Do not use the battery charger if damaged. Do not open the battery charger yourself; charger must be repaired by qualified personnel using original spare parts.
3. The charger is designed to use a standard household 120-240 V~ 50Hz power source, ensure that the plug matches the outlet.
4. Never modify the plug in any way, this will reduce the risk of electric shock.
5. Do not mis-use the charger cord. Never use the cord for carrying, pulling or unplugging the charger. Keep cord away from heat, oil, sharp edges or moving parts. Damaged or entangled cords increase the risk of electric shock.
6. Make sure the charger cord is situated so that it will not be stepped on, tripped over or get damaged.
7. Keep the battery charger clean. Contamination can increase the risk of electric shock.
8. Protect the battery charger from rain and moisture. If water accesses the battery charger there is an increased risk of electric shock.
9. Battery will heat up whilst charging. To reduce the risk of fire, do not operate battery charger on flammable

## GENERAL SAFETY WARNINGS

- surfaces such as paper or textiles.
10. The temperature range over which the battery pack can be charged is typically between 5°C-45 °C. Attempts to charge out with the prescribed temperature range may automatically be blocked by the protection circuitry of the battery pack. Longest life and best performance can be obtained if the battery pack is charged at room temperature.
  11. Disconnect charger from the power supply when not in use. This will reduce the risk of electric shock or damage to the charger.

### Battery pack

1. Fully charge battery pack before first use.
2. Recharge battery pack immediately when the power output starts to slow. **DO NOT CONTINUE TO USE PRODUCT WHEN BATTERY LEVEL IS LOW.**
3. To prevent serious damage to the battery, charge in temperatures above 5°C or below 45°C. Longest life and best performance can be achieved when battery is charged at room temperature.
4. If the battery temperature is above 45°C it must be allowed to cool before putting it into the charging station.
5. To reduce the risk of explosion, ensure the battery pack is not left in the sun for extended periods of time and that it is kept away from fire.
6. Do not carry individual battery packs in your pockets or bag as they could short-circuit against other metal items.

## GENERAL SAFETY WARNINGS

7. Should a Li-Ion battery catch fire, ensure to use the correct fire extinguisher to combat the fire. **DO NOT THROW WATER ON A BURNING LI-ION BATTERY.**
8. If the battery pack becomes too hot during charging, disconnect and switch off immediately. Contact the service centre directly.
9. Do not attempt to open the battery yourself.
10. When battery pack is not in use keep it away from other metal objects such as paperclips, coins, keys, nails, screws or other small metal objects that can make a connection from one terminal to another.

### Safe handling

#### DANGER

- The user must use the appliance as intended. The person must consider the local conditions and must pay attention to other persons in the vicinity when working with the appliance.
- The appliance may not be operated in explosive atmospheres.
- If the appliance is used in hazardous areas the corresponding safety provisions must be observed.
- Do not use the appliance if it fell down, is visibly damaged or leaking.
- Keep packaging films away from children, there is a risk of suffocation!

## GENERAL SAFETY WARNINGS

### WARNING

- The appliance must not be operated by children or persons who have not been instructed accordingly.
- This appliance is not intended for use by persons with limited physical, sensory or mental capacities or lacking experience and/or skills, unless such persons are accompanied and supervised by a person in charge of their safety or they have received precise instructions on the use of this appliance and have understood the resulting risks.
- Children must not play with this appliance.
- Supervise children to prevent them from playing with the appliance.
- Keep appliance out of reach of children as long as it is switched on or hasn't cooled down.
- Cleaning and user maintenance must not be performed by children without supervision.
- Operate or store the appliance only in accordance with the description or illustration.

### CAUTION

- Create stability for the appliance prior to any work on or with the appliance to prevent accidents or damage.
- Never fill solvents, solvent-containing liquids or undiluted acids (e.g. detergents, petrol, paint thinner, and acetone) into the water reservoir as these substances corrode the materials used in the appliance.
- Never leave the appliance unattended as long as it is in operation.

## GENERAL SAFETY WARNINGS

- Keep parts of the body (e.g. hair, fingers) away from the rotating cleaning rollers.
- Protect your hands when cleaning the floor head due to a danger of injury from sharp objects (e.g. splinters).
- Keep connection cable away from heat, sharp edges, oil and moving parts.

## ATTENTION

- Only switch on the appliance when the fresh water tank and waste water tank are fitted.
- The device may not be used for vacuuming sharp objects or large objects (e.g. glass shards, gravel, toy parts).
- Do not fill the fresh water container with vinegar, decalcification agents, essential oils or similar substances. Also take care to ensure that these substances are not vacuumed.
- Only use this appliance on hard floors with waterproof coatings (e. g. enamelled tiles, Linoleum).
- Do not use the appliance for cleaning of carpets or carpeted floors.
- Do not use the appliance over the floor grilles of convector heaters. The appliance is not able to take in the water discharged when used above grilles.
- In case of longer breaks in operation and after use, switch off the device at the main switch / device switch and pull the charger's mains plug.
- Do not operate the appliance at temperatures below 0 °C.
- Protect the unit from rain. Do not store outside.

## SYMBOLS

### Safety symbols

The purpose of safety symbols is to attract your attention to any possible dangers. The safety symbols and their explanations deserve your careful attention and full understanding. The symbol warnings do not, by themselves, eliminate any danger. The instructions and warnings they give are no substitute for proper accident prevention measures.



**WARNING:** Be sure to read and understand all safety instructions within this operator's manual, including all safety alert symbols such as "**DANGER**", "**WARNING**", and "**CAUTION**" before using this tool. Failure to follow all instructions listed below may result in electric shock, fire and/or serious personal injury.

**SAFETY ALERT SYMBOLS:** Indicate **DANGER**, **WARNING**, or **CAUTION**. May be used in conjunction with other symbols or pictographs.

### Symbol meanings

This page depicts and describes safety symbols that may appear on this product. Read, fully understand and follow all instructions on the machine before attempting to assemble and operate.



## SYMBOLS

 To reduce the risk of injury, user must read instruction manual carefully.

 WEEE symbol. Waste electrical products should not be disposed of with household waste. Please recycle where facilities exist. Check with your local authority or local store for recycling guidelines.

 The product complies with the applicable European directives and an evaluation method of conformity for these directives was done.

 Conforms to relevant UK regulatory requirements.

## SYMBOLS

### Warning symbols on the battery pack

 To reduce the risk of injury, user must read instruction manual carefully.

 Do not throw into water.

 Do not throw on fire.

 Do not subject the battery to strong sunlight over long periods of time. Do not leave on a heater (max.45°C).

 Batteries contain Li-ion. Do not dispose of waste batteries in domestic waste. Contact local authority to find out how to dispose of batteries.

 The product complies with the applicable European directives and an evaluation method of conformity for these directives was done.

 WEEE symbol. Waste electrical products should not be disposed of with household waste. Please recycle where facilities exist. Check with your Local Authority or local store for recycling advice.

## SYMBOLS

### Warning symbols on the charger



To reduce the risk of injury, user must read instruction manual carefully.



The charger is for indoor use only.



Double insulation



WEEE symbol. Waste electrical products should not be disposed of with household waste. Please recycle where facilities exist. Check with your Local Authority or local store for recycling advice.



The product complies with the applicable European directives and an evaluation method of conformity for these directives was done.



SMPS (Switch mode power supply unit) incorporating a short-circuit-proof safety isolating switching power supply.



SMPS (Switch mode power supply unit)



Conforms to relevant UK regulatory requirements.

## TECHNICAL DATA

<b>Model</b>		<b>LW F28</b>
Nominal voltage of product with battery		12V
Rated power of appliance		40 W
Working width		260 mm
Roller revolutions per minute		500 rpm
Fresh water tank		300 ml
Waste water tank		120 ml
Weight		2.2 kg
<b>Battery pack Model</b>		<b>AL F40</b>
Battery capacity		4 Ah
Battery charging time Max.		80 min
<b>Battery charger Model</b>		<b>XZ1300-3000G/ XZ1300-3000GB</b>
Input		120-240V AC, 50/60Hz 1.0A
Output		13V , 3A
Protection class		II

## DESCRIPTION OF PRODUCT

### Parts description (Fig. A)

1. ON/OFF switch
2. Battery pack release button
3. Battery pack
4. Handle tube
5. Stand support
6. Rear wheel
7. Collection tank
8. Roller release button
9. Roller
10. Fresh water tank

### Check the delivery parts (Fig. B)

Remove the machine from its packaging carefully and make sure that all of the following parts are present:

- a. Main floor cleaner
- b. Fresh water tank
- c. Stand support (3 separate parts )
- d. Battery pack
- e. Manual
- f. Charger
- g. Cleaning brush



**WARNING:** If any parts are damaged or missing, do not operate this tool until these parts have been replaced. Failure to heed this warning could result in serious personal injury.



**NOTE:** Always recycle the packaging in accordance with local recycling guidelines.

## INSTALLATION

### Assemble the main handle (Fig. C)

1. Align the main handle with the tube.
2. Insert the main handle into the tube, make sure the handle is fully locked in position.

### Attach the handle to the working head (Fig. C)

1. Align the tube with the working head.
2. Insert the main handle into the socket, make sure the tube is fully locked in position.

### Assembly the stand support (Fig. D)

1. Pinch the metal wire together and then install the wire into the stand base.
2. Install the holder onto the wire.

### Install the fresh water tank

1. Firstly remove the rubber seal and fill with the fresh water tank with water or detergent. **(Fig. E)**
2. Install the rubber seal and make sure the rubber seal is firmly inserted.
3. Insert the water tank into the socket on the working head. **(Fig. F)**

**NOTE:** Do not over fill the water upon the **MAX** line.

## OPERATION

### Charging the battery pack

**NOTE:** Remove the battery pack from the charger after it has been fully charged.

**NOTE:** Battery should be fully charged before first use.

**NOTE:** Make sure the mains voltage is the same as rating label which is located on the charger.

1. Connect the charger to a power supply.
2. To insert the battery pack into the charger, align the raised ribs of the battery pack with the grooves of the charger then push it in. **(Fig. G)**
3. The green LED light on the battery pack will flash continuously during normal charging.
4. After charging is complete, the green LED light will turn off.

### Power indicator (Fig. H)

This Li-Ion battery pack is equipped with a power indicator which is used to show the battery pack's remaining charge. The LEDs will stay lit for approximately 4 seconds.

### To obtain the best life from the battery

1. Never allow the battery to completely discharge before recharging. The battery pack should be placed on the charger whenever the battery pack is noticeably running down or the tool no longer performs a task it previously performed.
2. Avoid conducting short charges. Make sure that the battery is fully charged each time by allowing the charger to complete its full charging cycle.
3. Avoid allowing loose items like screws or nails etc. to be stored with battery packs as these or similar items can short battery packs and cause a fire or explosion.
4. Always unplug the charger when not in use and store in a dry and secure place.
5. Avoid charging or storing your battery in temperatures below 5°C and above 45°C.
6. After use, allow the battery to pack to cool down for approximately 30 minutes before attempting to recharge.

### Inserting and removing the battery pack

#### Insert the battery pack (Fig. I)

Align the battery pack with the handle connectors. Push the battery pack into the place until you hear a click. This means the battery pack has been locked in position.

#### Removing the battery pack from the tool (Fig. J)

Push the battery pack release button, and then pull out the battery pack.

## OPERATION

### Before operation

#### ATTENTION

- The device can only collect dried dirt and liquids (max. 120 ml).
- Brush or vacuum the floor before starting work. This removes dirt and loose particles from the floor before the wet cleaning commences.
- Before use, check the floor for water consistency at suspect areas. Do not clean water-sensitive coatings, such as untreated cork floors (moisture ingress is possible which may damage the floor).
- Clean the floor by moving the appliance back and forth at a similar speed as if you were vacuum cleaning.
- If the floor is especially dirty, let the appliance glide slowly across the floor.
- Pressure does not need to be exerted on the device.

### Start working

#### ATTENTION

- After switching on the appliance, the cleaning rollers will begin to rotate. Hold the handle firmly to prevent the appliance from moving forwards by itself.
- Make sure the fresh water tank is filled with water and the waste water tank is fitted in the appliance.

To switch on the appliance press the ON/OFF switch. **(Fig. K)**

Move the unit back and forth several times until the rollers are sufficiently moistened.

### Emptying the waste water tank

Unlock the waste water tank. Remove it from the floor head. **(Fig. L)**

- Open the tank cap. Empty the waste water tank. **(Fig. M)**
- Clean waste water tank and its cap with tap water, depending on the degree of soiling.
- Re-insert the caps of the waste water tank.

**NOTE:** It is suggested to empty the water tank after daily cleaning.

**NOTE:** Empty the tank when the waste water reaches the **MAX** line, otherwise it will occur the leakage.

### Cleaning the roller

- Press the release button on the side to release the roller and then pull out the roller. **(Fig. N)**
  - Clean the roller with fresh water, and let dry on the stand support. **(Fig. O)**
- WARNING:** Do not clean the roller which is not detached from the device!

## OPERATION

### Replacing the roller

Slide the roller onto the motor and align the roller onto the motor drive and then click back into place on the housing

## MAINTENANCE AND STORAGE

**WARNING:** Before performing any maintenance or cleaning work, always ensure that the battery pack has been removed.

**WARNING:** Always wear heavy duty gloves when adjusting or cleaning, especially when handling sharp objects.

### Cleaning the product

- Use a soft brush to remove accumulated dust and debris. Especially the outlet holes under the housing. Wear safety glasses to protect your eyes whilst cleaning.
- Wipe down the product enclosure with a slightly damp cloth. Do not spray the unit with water. Water may destroy the switch unit and the electric motor.

### Maintenance

1. Keep all nuts, bolts and screws tight to ensure that the machine is in a safe working condition.
2. Examine the machine and replace worn or damaged parts for safety.
3. Never use your hands /fingers for cleaning the housing --always use a the brush due to sharp scraper edge blade.

### Battery maintenance

Use the following procedures to achieve the best battery life:

1. Protect the battery against moisture and water.
2. Store the battery only within temperature range of 5 °C to 45 °C. Do not leave the battery in direct sunlight for extended periods of time.
3. Clean the battery regularly with a soft, clean and dry brush.
4. If you do not use the product for a long time, remember to charge and discharge the battery pack once every 6 months.

### Storage and transport

#### Storage

##### ATTENTION

- To prevent odours developing, the fresh water and waste water tank must be completely emptied prior to storing the appliance.
- Allow wet rollers to dry in the air, do not place wet rollers in closed cupboards to dry.
- Store the appliance in a dry room.

#### Transport

Use the original packaging to ship whenever possible.

## TROUBLESHOOTING



**WARNING:** Before performing any repair work, always ensure that the battery pack has been removed.



**WARNING:** Always wear heavy duty gloves when adjusting or cleaning, especially when handling sharp objects.

Fault/malfunction	Cause	Remedy
The device cannot be switched on	Battery is not correctly inserted	Remove the battery and reinsert
	Battery is empty	Charge the battery pack
	Motor damaged	Contact with after-service centre
Poor cleaning performance	Rollers are too dry	Switch ON the device and operate more than 1-2 mins
	Roller used for a long time and get worned	Replace a new roller
	Not enough fresh water in the tank	Fill in the fresh water in the tank
	Waste water tank full	Pull out the waste water

## DECLARATION OF CONFORMITY

To the provisions of Council Directives

We  
**MEROTEC GmbH,**  
**Otto-Brenner-Str. e 8,**  
**47877 Willich/ Deutschland**

**Declare that the product:**  
 Machine Description: 12V Floor cleaner  
 LW F28/ Q0QT-SP01-260ZA  
 Function: Clean floor

**Complies with the essential health and safety requirements of the following directives:**

Low Voltage Directive 2014/35/EU  
 Electromagnetic Compatibility Directive 2014/30/EU  
 EC Directive 2011/65/EU and its amendment Directive (EU) 2015/863 (RoHS)

**Standards and technical specification referred to :**

EN 60335-1:2012+A11+A13+A14+A2+A15  
 EN 60335-2-10:2003+A1  
 EN 55014-1:2017+A11  
 EN 55014-2: 2021

Authorized Signatory  
 Date: 23.03.2022

Signature:   
 Place: Willich  
 Name: Roland Menken  
 General Manager

MEROTEC GmbH,  
 Otto-Brenner-Str. e 8,  
 47877 Willich/ Deutschland

